

ELECTRICITY

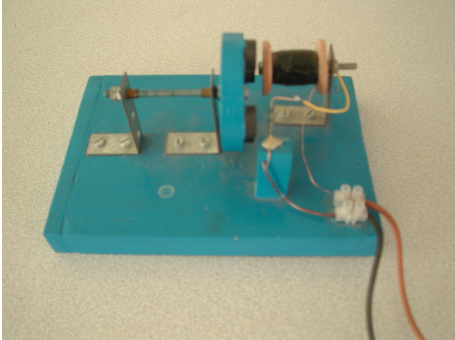

AND

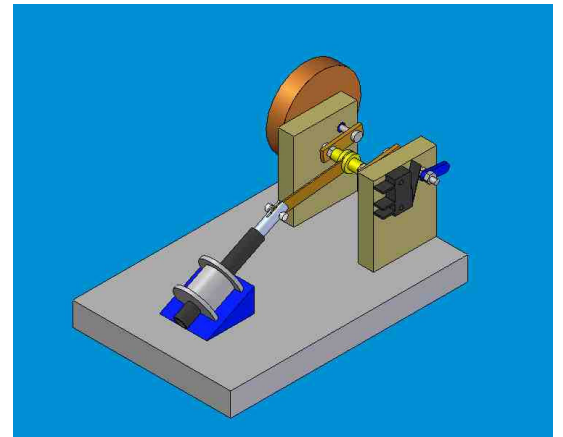

MOVEMENT



ELECTROMAGNETIC PISTON ENGINE

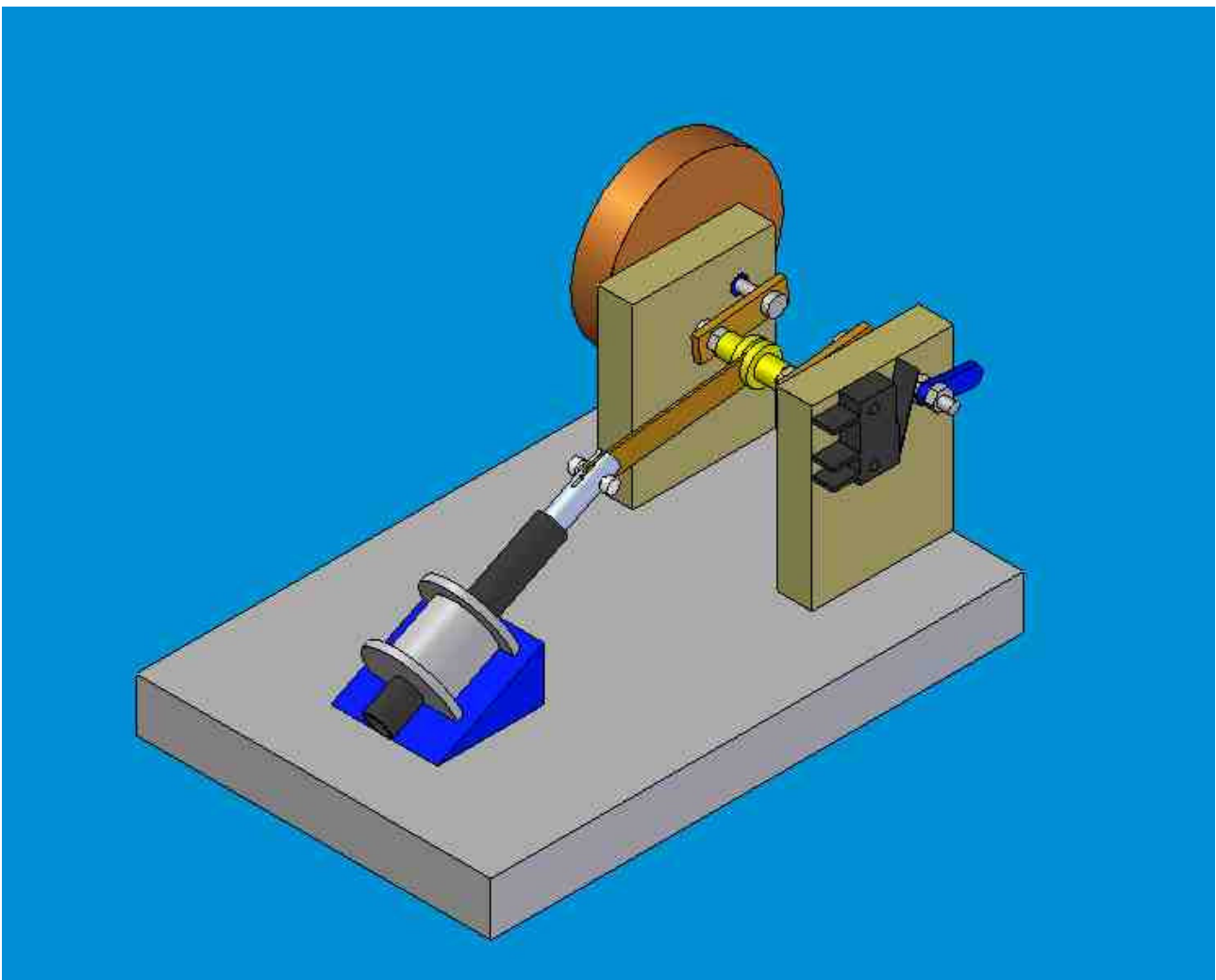

Exploded drawing

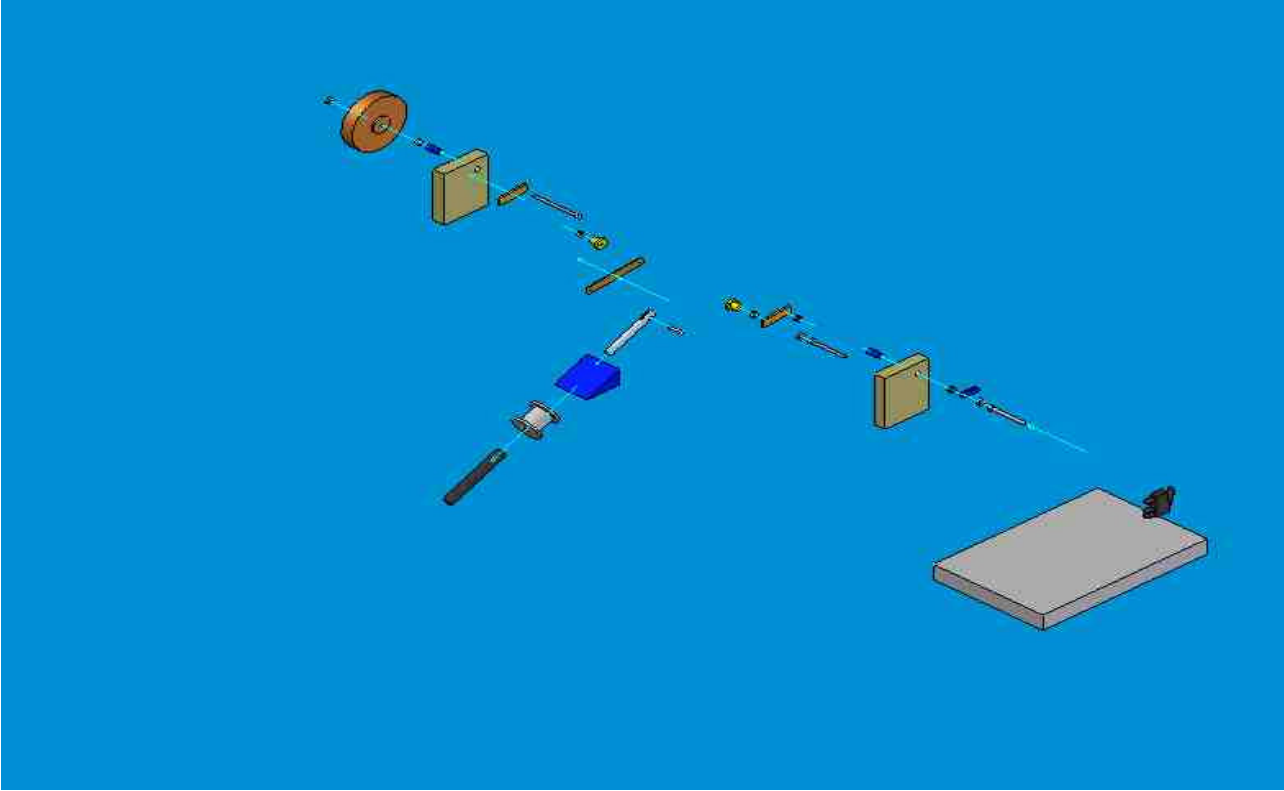

Preparation of the elements

To construct the two supports of the axis of the crank using a strip of 10 x 40 x 50mm, as it is indicated in the figure

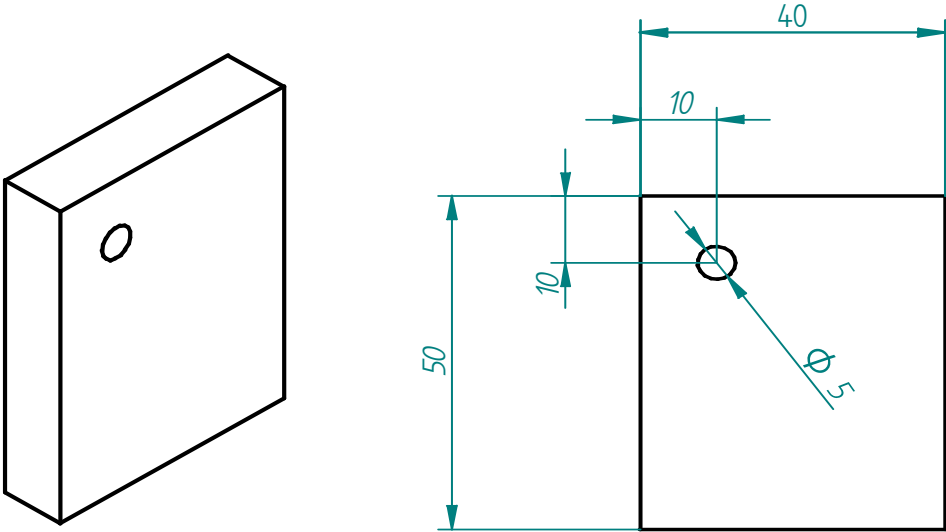

Assembly of the sockets wood supports and bases of the engine

To insert the sockets bearings in the perforation of the supports as it is indicated in the figure.

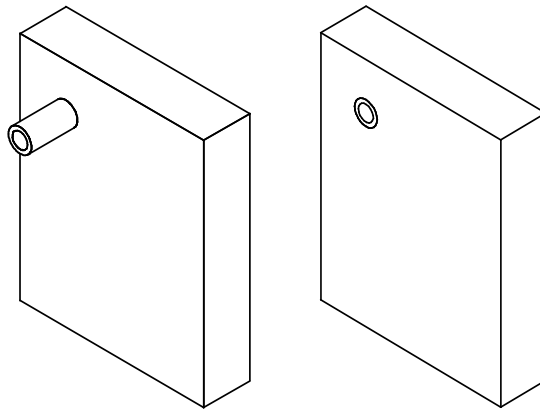

To glue and to stick only one of the supports with the measures given in the plane. The other support will stick after the crank is ensambled, since otherwise we could not place it by lack of space

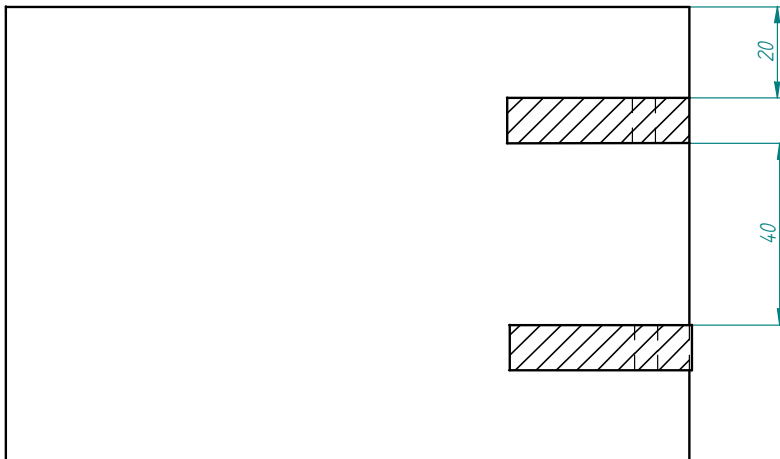

Construction of the crank

For this assembly we will use a metric screw of 3 by 40 of length, located to the right of the figure (N°1), two metric screws of 3 by 30 of length (N°2), two drilled billets (N°3), two tops situated between the billets (N°4), and the billet of the cam (N°5), the nuts held all the set leaving it fixed except the cam that turned due to the tops that are introduced in the screw, reason why is necessary to try that they have the sufficient clearance and they do not press the billet

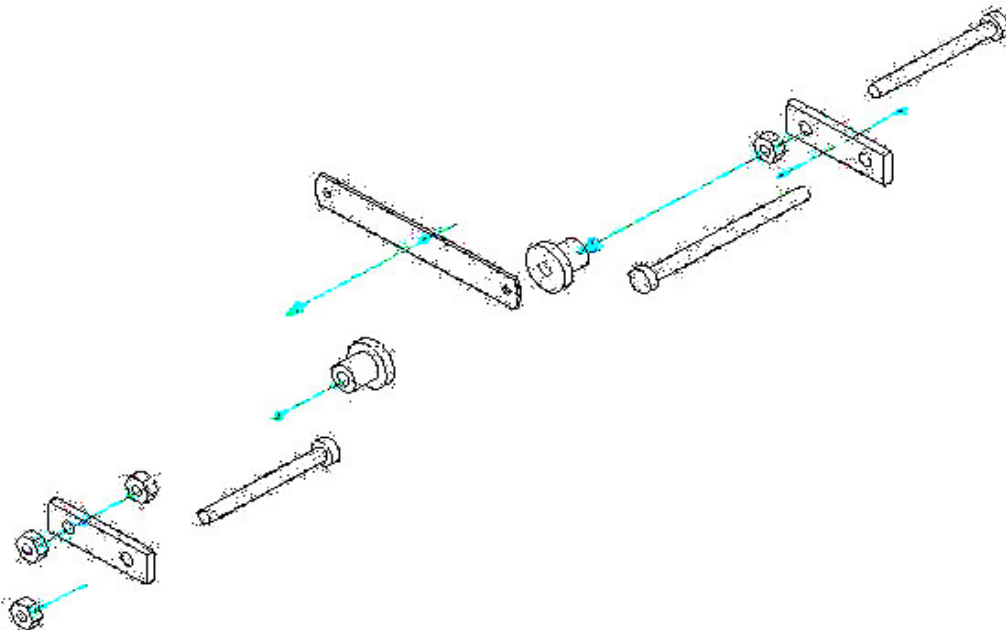
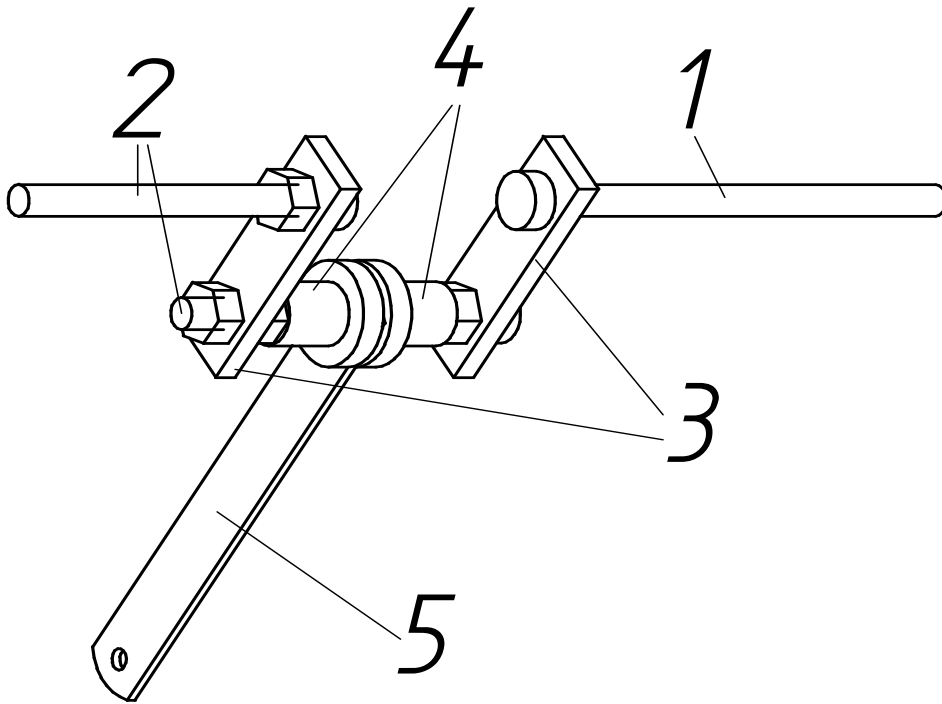

Positioning of the crank

Once finished the assembly of the crank we will come to place it in the wood supports fixing, once placed the crank and verifying that turns freely, the support of wood to the base that previously we left without placing, for it we will use glue and leave is dried trying not to move the pieces

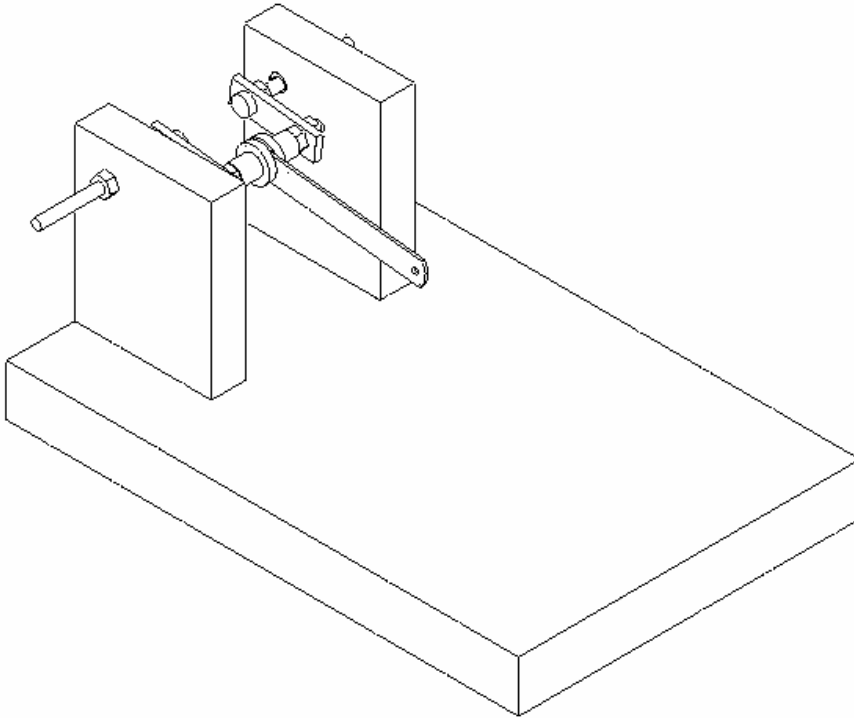

Positioning of the steering wheel and the cylinder of the piston

Once finished the assembly and already having itself dried the glue with that we have fixed the base we will place the steering wheel fixing it with a nut by the outer part, and will hold the piston with a pin to the billet of the cam.

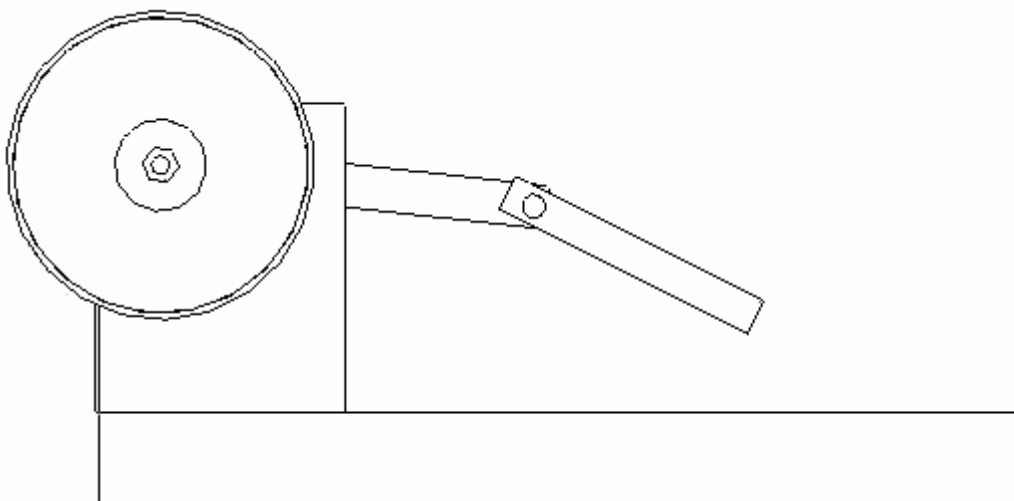

Construction of the wound

In order to make the wound, we will use the spool and enameled wire of 0.3 of diameter and 2 meters in length.

With the enameled wire we will give revolutions in the interior of the reel considering, that there is to leave both extremes free, in order to make the corresponding connections.

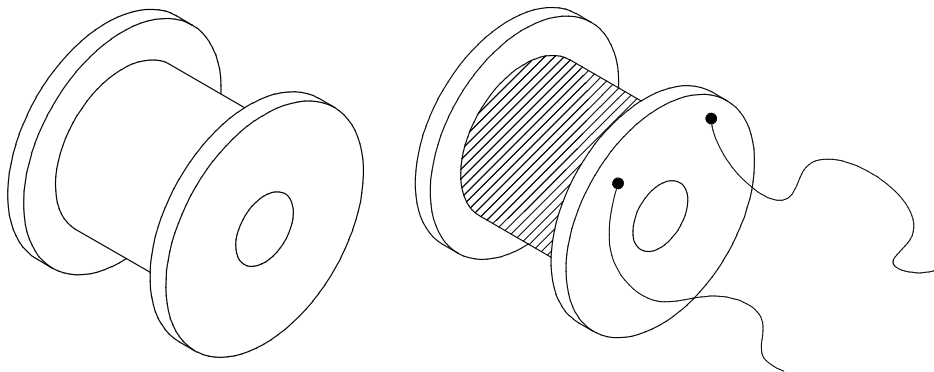

Assembly of the wound in the engine

Next we will continue with the assembly of the coil and the cylinder, that will be supported on a wood wedge so that takes the necessary angle, so that it coincide with the piston of the engine. In the first place, we will fix the wedge with glue to the base of the engine, according to the measures of the drawing.

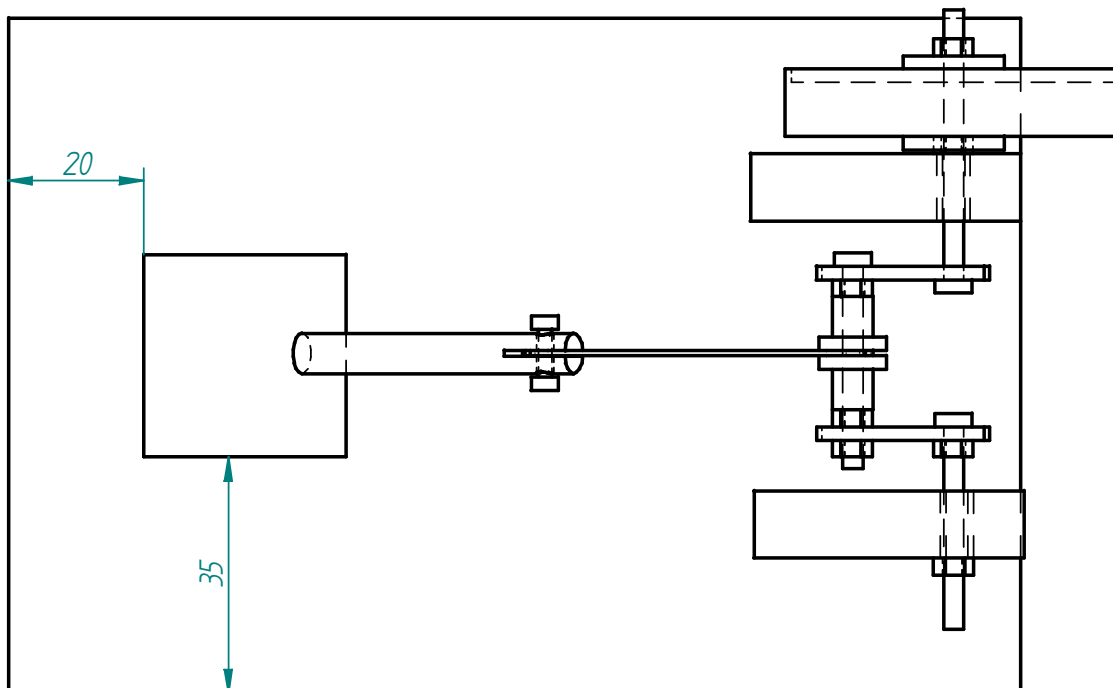

Once dried the glue we will place the cylinder inside the coil and will place the set on the wood wedge introducing the piston within the cylinder, and with termoseales we will fix the reel on the wedge, not without before assuring that the steering wheel of the engine moves the piston enters correctly into the cylinder. We have to try that the piston and the cylinder have the smaller possible friction so that the electromagnet can drag it facility.

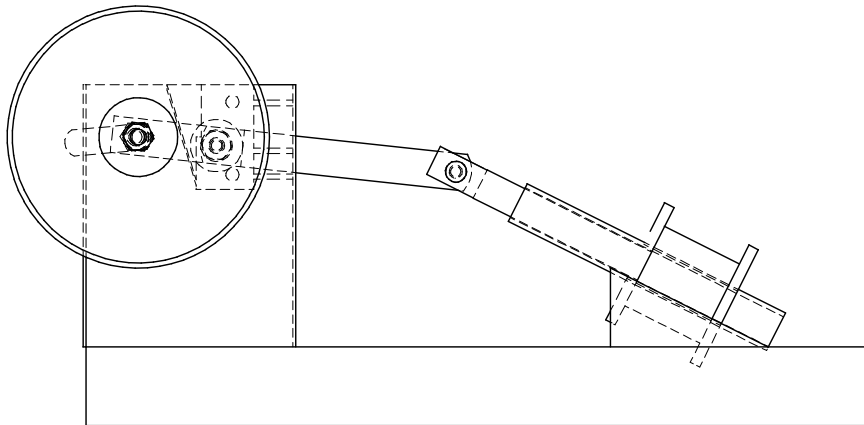

Assembly of the microswitch and the actuator

Next, we will place the microswitch and the actuator in the opposite face of the support to where the this steering wheel is. The actuator we will provisionally fix to the screw that exceeds of the support. I say provisionally due to when the engine is finished we will have to fit it so that actued on the switch at the precise moment, and the microswitch we will fix with termosealer to the outer face of the support, considering that the actuator when turning with the screw must touch, when pass opposite the switch, the billet that that has got.

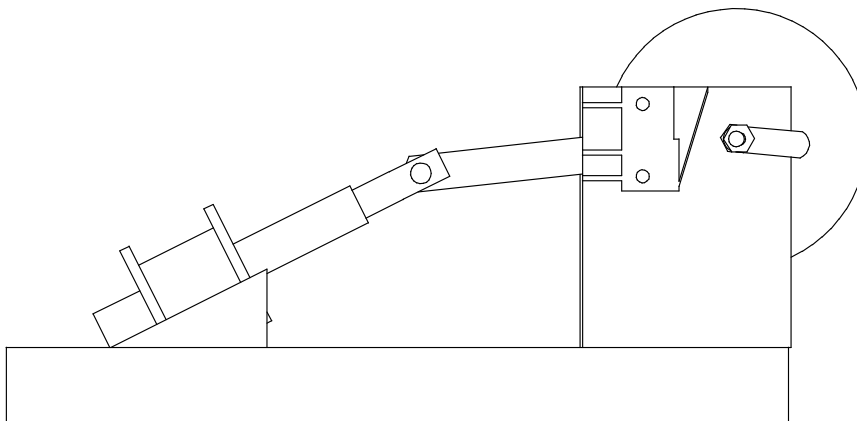

Connections

The microswitch is in fact a commutator, therefore, has one common tag and 2 tags, one of closed circuit in rest, (when we pressed the switch opens the circuit) and another one of circuit opened in rest (when we pressed the switch closes the circuit). We will take an end of the wire of the coil to the common one of micro, and will weld a wire to the tag open in rest. This wire we will connect to a terminal strip. The other end of the wire we will connect directly to the terminal strip, as it indicates the scheme. From the two tags of the strip will leave two wires to the net.

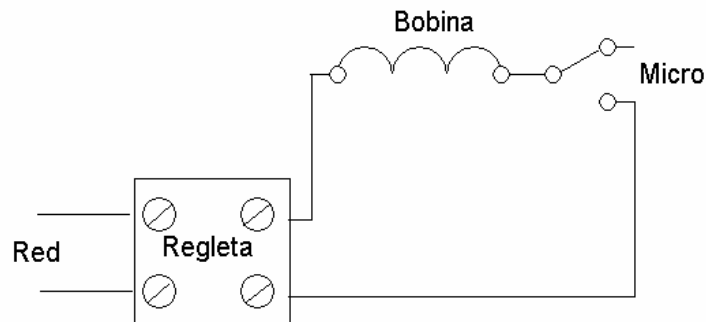

Operation

The operation is very simple, nevertheless it is necessary to be extremely precise at the time of fitting the actuator of the microswitch.

When the microswitch is pressed by the actuator, the coil receives the current of the net, and therefore it creates a magnetic field that it attracts the piston. When the piston is attracted towards the coil, the crank moves forward moving the actuator and lets press micro, therefore the coil remains without current. At this moment we could think, if it does not have current why it gives a revolution until it completes and micro is acted again? It is very simple, this is due to the steering wheel inertia.

So that all the process works correctly the actuator must be fit, of such form that presses micro at the exact moment that the steering wheel is going to stop, of such form that the impulse that it provides to it will be enough in order to giving another revolution.